



**SAVEAIR**  
Technologies Pvt Ltd



# Product Catalogue

Contact For Any Enquiry

📍 25/1, 12<sup>th</sup> Avenue, Ashok Nagar, Chennai-600083.

☎ 044- 4858 4456 📞 9840261043

✉ [marketing@saveairtechnologies.com](mailto:marketing@saveairtechnologies.com)

🌐 [www.saveairtechnologies.com](http://www.saveairtechnologies.com)



# ALARM ANNUNCIATORS

.....  
2-48 Windows Alarm Annunciators  
.....

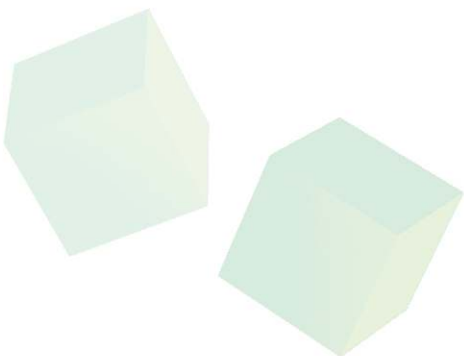

# Alarm Annunciators

- Standard models available from 2 to 48 windows
- Choice of 3 window sizes and 6 different window colours
- Optically isolated fault inputs with wide fault input voltage range (12 - 240V AC/DC +/-10%)
- Field selection for NO / NC fault input contacts, grouping of alarms, window size configuration
- Space saving due to lower depth of only 100mm
- Integral push buttons for Test, Acknowledge, Mute and Reset operations
- Four SPDT relay outputs (2 for grouping, 1 for external hooter, 1 for ring back sequence)
- 7 Field selectable operation sequences as per ISA standard
- Integral buzzer for audible alarm output of 80 dB
- Communication interface with RS485 Modbus RTU protocol
- Replaceable LEDs, Fast Scan, Manned / Unmanned, Supervisory Relay & Supply fail annunciation available



## Working Principle

---



Whenever there is a change of input contacts from Normally Open to Close or from Normally Close to Open position, annunciator changes from rest condition to alarm condition.

Hence there is an immediate recognition of fault input which will have a corresponding visual and audio alarm as per the particular selected program sequence.

The base unit of alarm annunciator has four programmable keys for Mute, Acknowledge, Reset & Test function. On pressing the Mute key the internal buzzer can be deactivated. Acknowledge key is used to accept the fault condition, Reset key enables to reset the alarm annunciator to its default state and Test key helps to perform the complete test of the system.



## Technical Specifications

Parameters	Fast Scan	Normal Scan
Supply Voltage (≡)	90 - 270 V AC/DC or 18 - 60 V DC	
Supply Frequency (AC)	50/60 Hz	
LED Indication (Green)	ON - Healthy / Manned Mode	ON - Healthy
	Blinking - Unmanned Mode [Slow Blinking Rate - 300msec ON, 3sec OFF] Blinking - Error [Fast Blinking Rate - 500msec Cyclic ON/OFF] Error: 1) User selected wrong windows configuration 2) Slave Communication error	Blinking - Error [Fast Blinking Rate - 500msec Cyclic ON/OFF] Error: 1) User selected wrong windows configuration 2) Number of windows are more than number of fault inputs.
No. of Windows	2 to 48 windows in different configurations	
Window Size	Small: 34x31mm, Medium: 68x31mm, Large: 68x63mm	
Window Colour	Red, Yellow, Blue, Green, Amber and White	
Illumination	Low power super bright white LEDs (replacable LEDs available)	Low power super bright white LEDs
Fault Input Signal	Potential free (NO/NC field selectable)	
Fault Input Voltage	Internal: 12V DC (Potential free)	Internal: 12V DC / External: 12V-270V AC/DC
Scan Time	10 msec	100 msec
Flash Rate	1) Fast flash - 0.5 Sec ON / 0.5 Sec OFF (60 flashes/Min) 2) Slow flash - 0.5 Sec ON / 1.5 Sec OFF (30 flashes/Min)	
Terminal	Pluggable terminal blocks for conductor up to 2.5mm <sup>2</sup>	
Output Relay Contact	4 C/O Relays (2 for grouping + 1 for external hooter + 1 for Ring back sequence)	
Relay Contact Rating	NO - 5A / NC - 3A @250V AC & NO - 5A / NC - 3A @ 30V DC (resistive), (Relay Actuation time 10 to 130ms after signal detection)	NO - 5A / NC - 3A @ 250V AC & NO - 5A / NC - 3A @ 30V DC (resistive), (Relay Actuation time 130ms after signal detection)
Audible Alarm Output	80 dB at 1 metre distance (In-built configurable Buzzer)	
Facia Type	Individual window lens, replaceable from front.	
Alarm Sequences	As per ISA standard (Field configurable) 1) Manual Reset (M-1) 2) Auto Reset (A-1) 3) Ring Back (R-1-12) 4) Auto Reset with No-lock(A-1-4) 5) Manual reset first out with no subsequent alarm flashing and silence push button (F2M-1) 6) Auto reset first out with no subsequent alarm flashing and silence push button (F2A-1) 7) Manual Reset (M-2) [Applicable for Fast Scan Module]	
Push Button Controls	Integral Push buttons for Test, Mute, Acknowledge and Reset functions. Provision of output connections for remote access of push buttons.	
Communication Port	Computer interface with RS 485 Modbus RTU protocol.	
Operating Temperature	-10°C to +55°C	
Storage Temperature	-15°C to +60°C	
Humidity	95% R.H.	
Mounting Type	Panel Mounting	
Certification	 	
Degree of Protection	Front panel IP40, Rear panel IP20	

### EMI / EMC Compliance

Harmonic Current Emissions  
ESD  
Radiated Susceptibility  
Electrical Fast Transient

Surge  
Conducted Susceptibility  
Voltage Dips and Interruptions(AC)  
Conducted Emission  
Radiated Emission

### Safety Compliance

Test Voltage Between I/P and O/P  
Impulse Voltage Between I/P  
And O/P  
Single Fault Test  
Insulation Resistance  
Leakage Current  
Pollution Degree

### Environmental Compliance

Cold Heat  
Dry Heat  
Vibration





IEC 61000-3-2 Class A  
IEC 61000-4-2 Level II Class A  
IEC 61000-4-3 Level III Class A  
IEC 61000-4-4 Level III (Power Supply and Input Signal with external supply),  
IEC 61000-4-4 Level III (Capacitive coupled on Input Signal and Remote keys with internal 12V supply),  
IEC 61000-4-4 Level II (Capacitive coupled on Communication)  
IEC 61000-4-5 Level IV (Power supply and Input Signal with external supply)  
IEC 61000-4-6 Level III Class A  
IEC61000-4-11 All VII Level Pass  
CISPR 11 / CISPR 14-1 Class A  
CISPR 11 / CISPR 14-1 Class A

IEC 60255-5, 2.5kV, 50Hz, 1Min  
IEC 60255-5, 5kV, 1.2/50us, 0.5J

IEC 61010-1  
UL 508 > 50 k  
UL 508 < 3.5 mA  
II

IEC 60068-2-1  
IEC 60068-2-2  
IEC 60068-2-6, 10 to 55Hz

# Ordering Information

	Cat. No.	Product Size	No. of Windows	Window Size	Keys
	AU1D8S	1D	8	Small	Small
	AU1D6SP	1D	6	Small	Big
	AD1D8S	1D	8	Small	Small
	AD1D6SP	1D	6	Small	Big
	AU2D16S	2D	16	Small	Small
	AU2D14SP	2D	14	Small	Big
	AD2D16S	2D	16	Small	Small
	AD2D14SP	2D	14	Small	Big
	AU3D24S	3D	24	Small	Small
	AU3D22SP	3D	22	Small	Big
	AD3D24S	3D	24	Small	Small
	AD3D22SP	3D	22	Small	Big
	AU4D32S	4D	32	Small	Small
	AU4D30SP	4D	30	Small	Big
	AD4D32S	4D	32	Small	Small
	AD4D30SP	4D	30	Small	Big

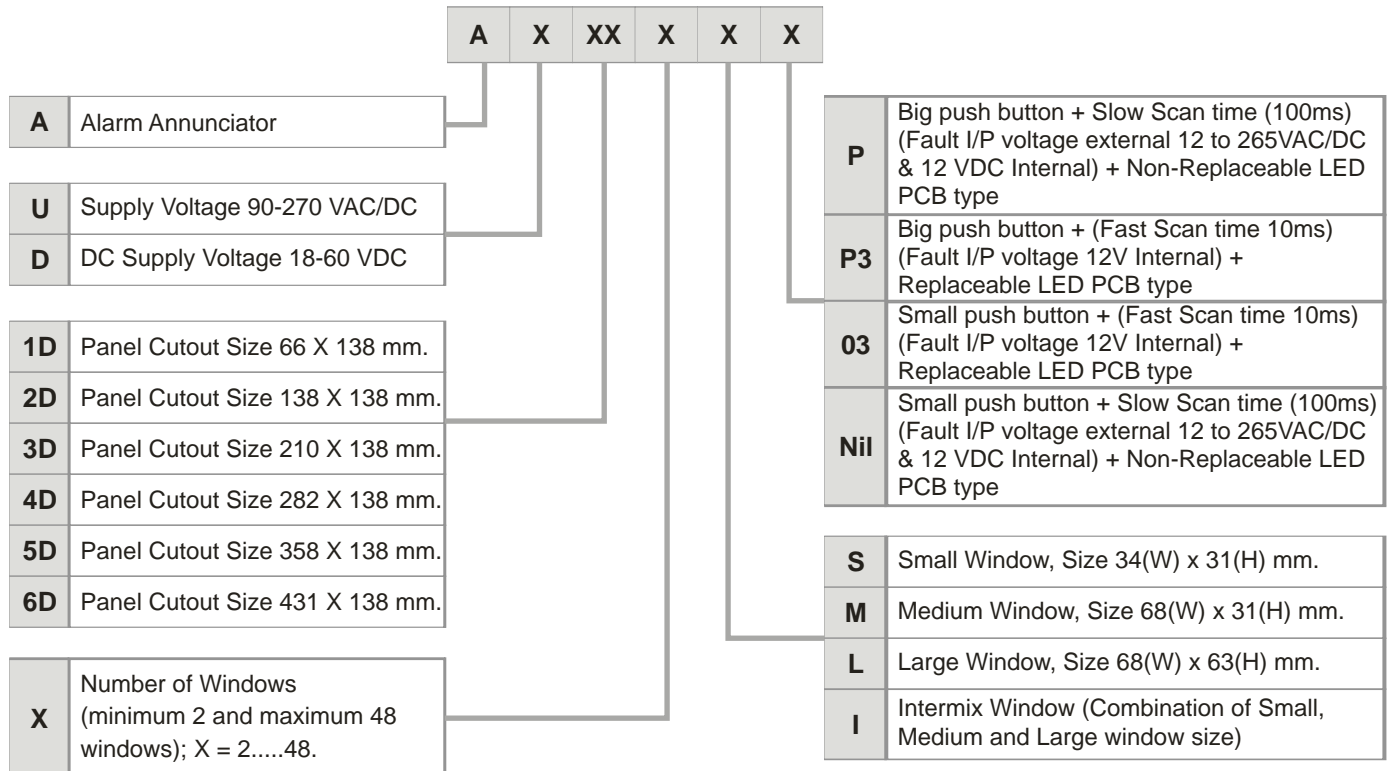

## Product Ordering code

**Note 1 :** For other customised products, use live product configurator available on our website to generate part number & enquiry request form: [www.gicindia.com](http://www.gicindia.com)

**Note 2 :** Legend templates are available on our website : [www.gicindia.com](http://www.gicindia.com)

# MOUNTING DIMENSIONS (mm)

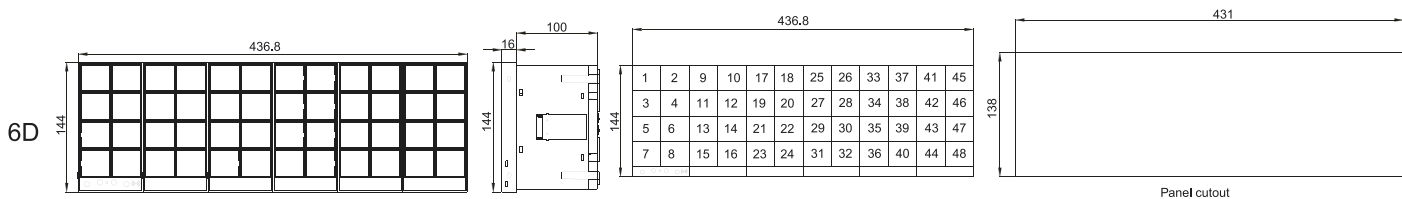
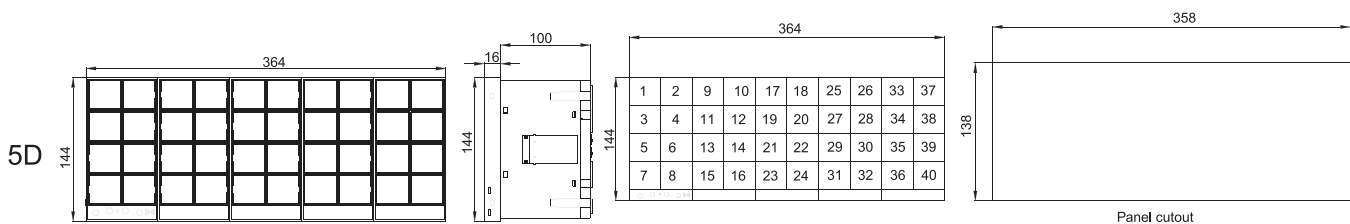
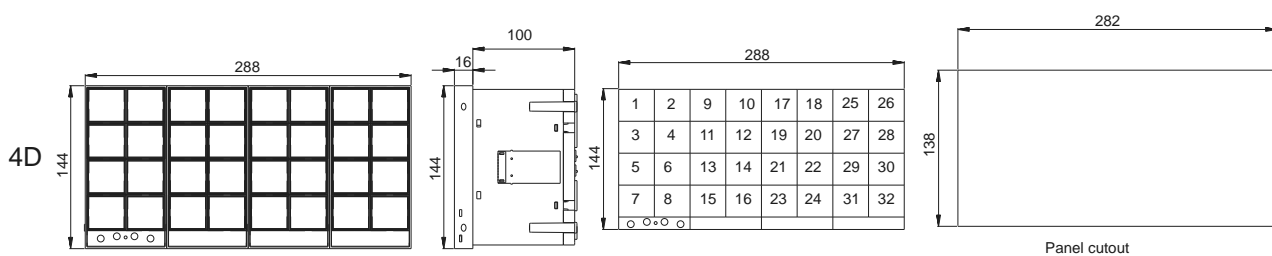
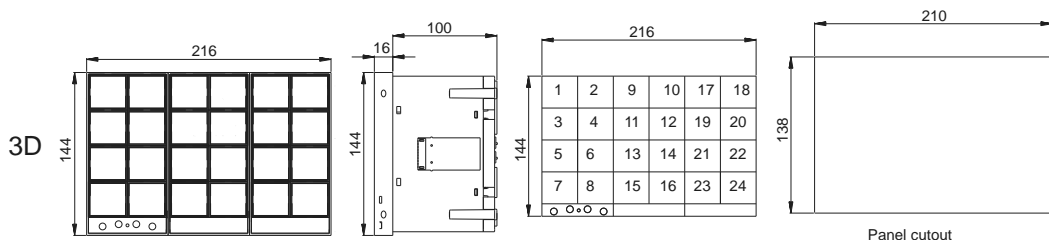
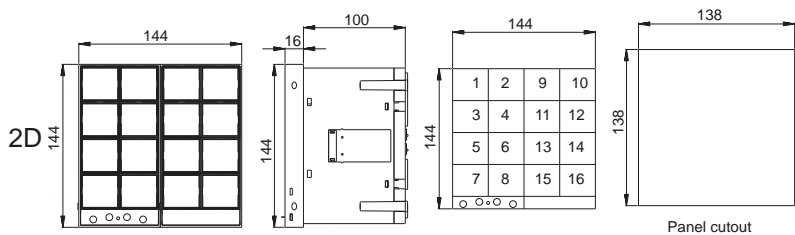
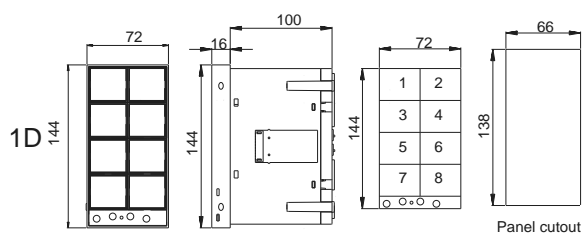

Weight with box (approx.): 1D=580g, 2D=950g, 3D=1320g, 4D=1690g, 5D=2060g, 6D=2430g

# CONNECTION DIAGRAM

## Fast Scan

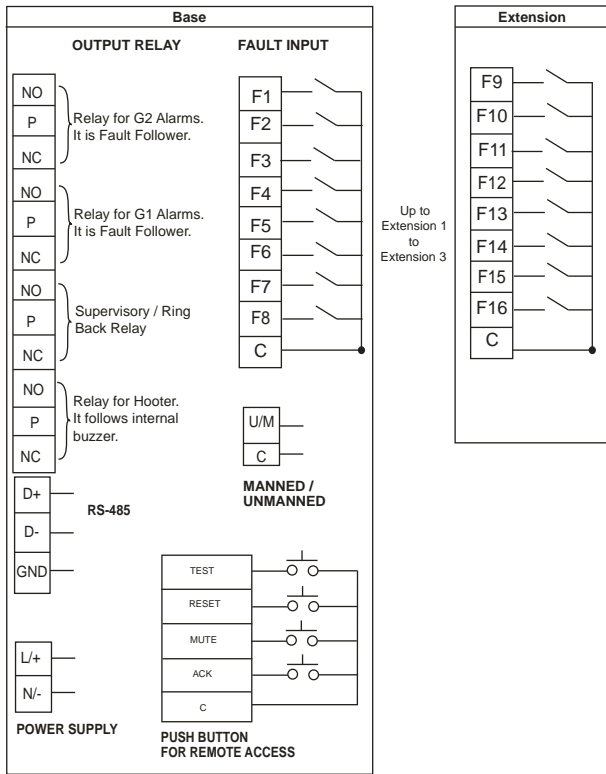

## Normal Scan

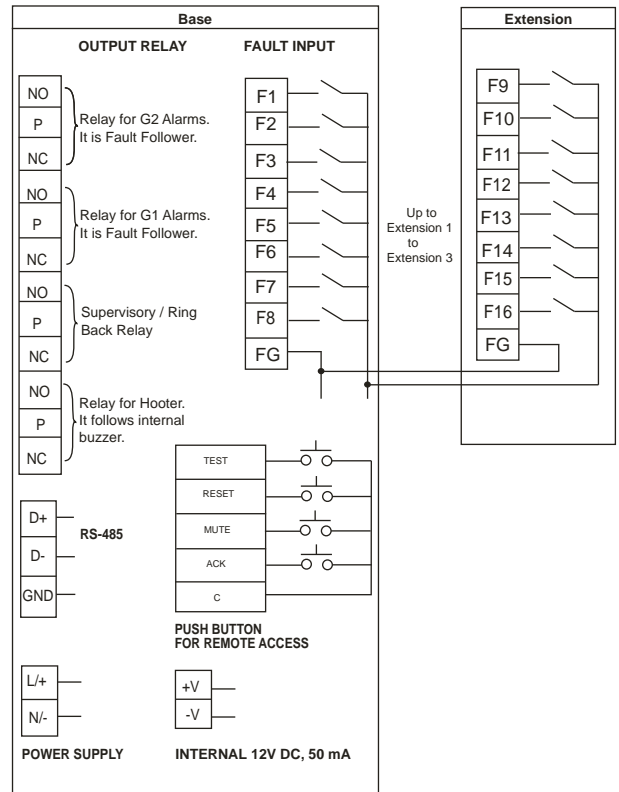

**Terminal Connection:** For Output Relay, Fault Input, Remote Keys,  
 Power Supply Connection: AWG 28 to 12, Ph1- 3.5mm, Torque 0.5Nm(4.5lb.in)  
 For Internal 12V supply, RS485 Connection: AWG 28 to 16, Flat- 2.5mm, Torque 0.2Nm(1.77lb.in)